

# KS系列-全自動糊盒機

## KS-Series of Auto. Folder Gluer

型號 Model: KS-1350/1350W/1350S

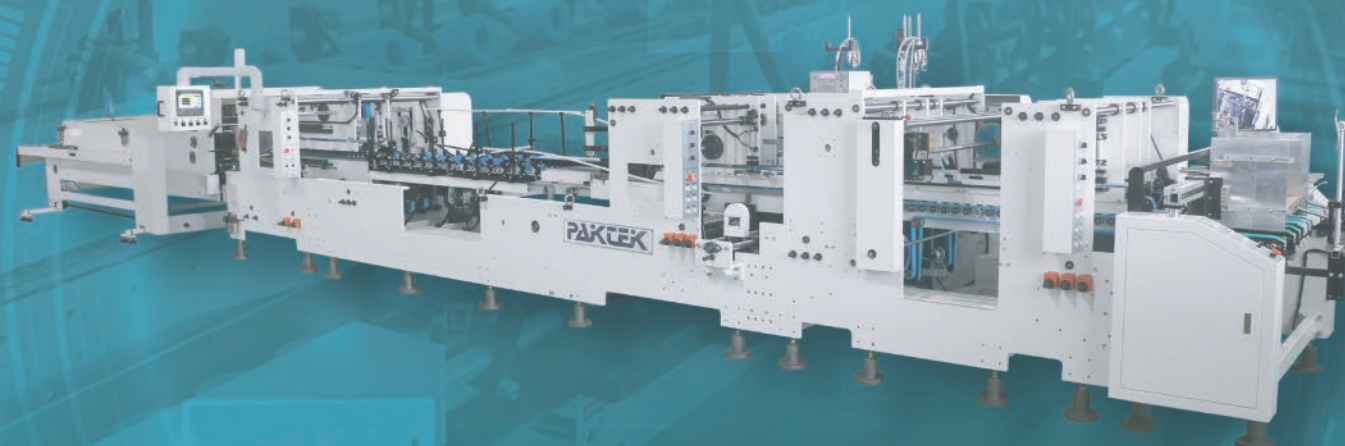

外型基礎圖 Floor Plan

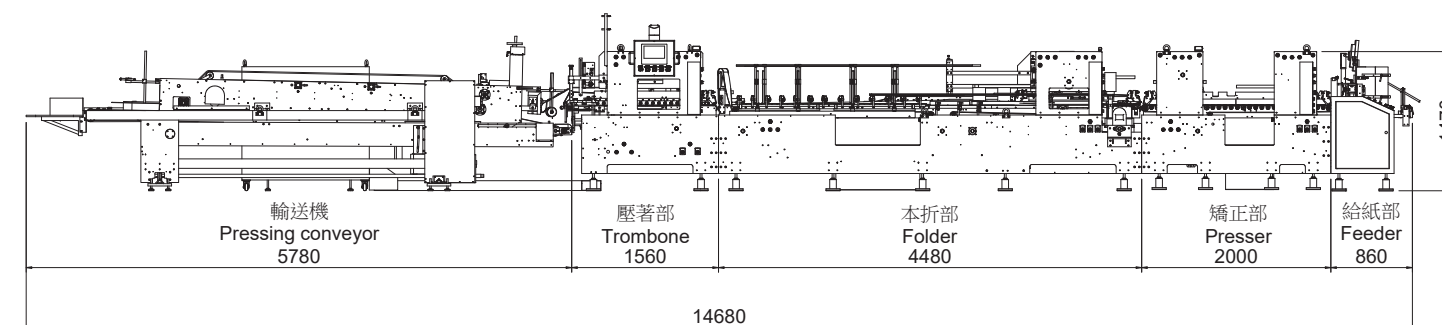
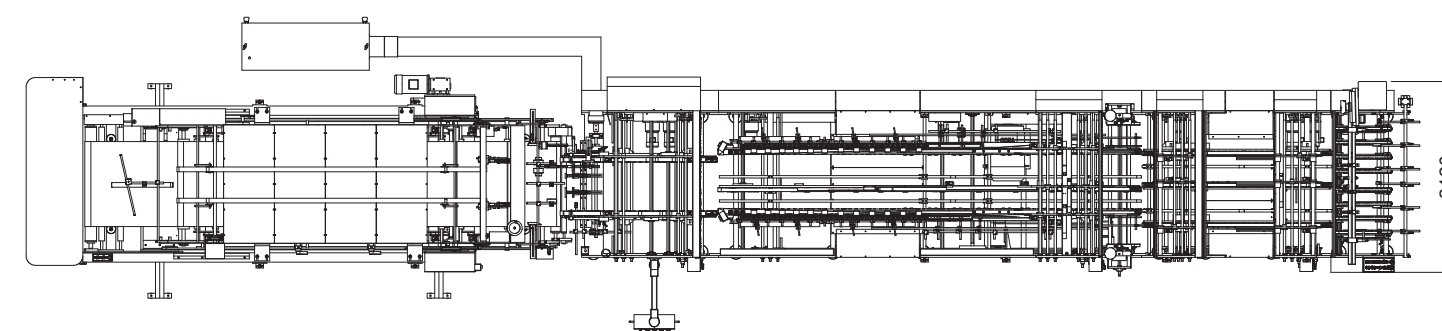

製作尺寸 Blank Size

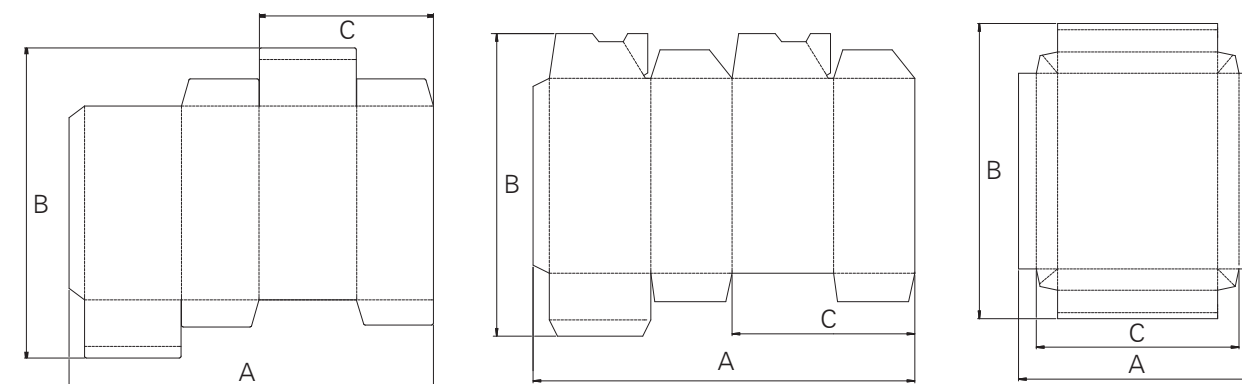

邊貼盒 / Straight Line

A. 115~1,350(1,450)mm  
B. 160~600mm  
C. 50~665mm

勾底盒 / Crash-Lock Bottom

A. 450~1,250(1,350)mm  
B. 190~600mm  
C. 220~610mm

兩側邊貼盒 / Double Sides

A. Max.800mm  
B. 160~800mm  
C. Min.320mm

機型/Model	KS-1350	KS-1350W	KS-1350S
可使用紙類/Used Materials	紙板, 瓦楞紙(N, E, B, A) / N, E, B, A-Flute Corrugated Board		
可製作盒型/Fundamental Pattern			
一般邊貼盒/Straight Line	●	●	●
兩側邊貼盒/Double Sides	○	○	○
勾底盒/Crash-Lock Bottom	○	○	—
使用接著劑/Used Glue	溶質性冷劑/Emulsion Type		
最高皮帶速度/Max. Belt Speed	20-250M/ min.		
總功率/Total Power	28 kw	32 kw	28 kw
體積/Dimension	14,797 x 2,021 x 1,596mm	14,680 x 2,120 x 1,470mm	14,571 x 2,022 x 1,896mm
給紙部 / Feeder			
吸風裝置與打孔皮帶/Suction Belts with Vacuum System	○	○	○
震動給紙裝置/Vibration Motor	●	●	●
獨立控制面板/Control Panel	●	●	●
毛刷輪裝置/Brush Wheel	●	●	●
給紙座氣壓升降/Right and Left Side Guiding Plate is Lifted by Pneumatic	●	●	●
矯正勾底部 / Regulator & Crash-Lock bottom			
壓線輪裝置/Creasing Wheel Device	●	●	—
UV磨邊器/UV Grinder	○	○	—
等離子處理機/Plasma Treater	○	○	—
上糊桶/Upper Glue Tank	○	○	—
上膠部 / Gluing Unit			
下糊桶/Lower Glue Tank	●	●	●
自動噴膠系統/Auto. Glue Injection System	○	○	○
貼膠(雙面膠/易撕帶)系統/Tape and Tear-Strip Applicator	○	○	—
本折部 / Final-Folder			
前後可移動式上壓桿/Segmented Upper Pressing Bar	●	●	●
外折帶可單獨調整速度/Folding Belt Speed Adjustment	●	●	●
本折部獨立調速系統/Final-Folder Independent Speed Control	●	●	●
電控移位板/Panel Movement by Motorization	●	●	●
壓著部 / Trombone			
計數踢板裝置/Kicker & Spraying for Counting	●	●	—
壓著部獨立調速系統/Trombone Independent Speed Control	●	●	—
輸送部 / Pressing Conveyor			
擺臂式氣壓輸送機/Air Cylinder Pressure Conveyor	●	●	—
推疊拍齊裝置/Down Stacking with Square Device	●	●	—
輸送部獨立調速系統/Pressing Conveyor Independent Speed Control	●	●	—
防撞推急停裝置/Anti-Collision Emergency Stop Device	●	●	—
電子配件 / Electronic Accessories			
觸控式人機介面/Intelligent HMI	●	●	●
遠端遙控器/Wireless Remote Controller	●	●	●
PLC自動定位系統/PLC Positioning System with Memory Function	○	○	—
PLC工作單記憶組/Product Set Memory Function	○ 100 set	○ 100 set	—
其他選購 / Other Optional			
CE安全規格/CE Certificate	○	○	○
計數堆疊排出系統/Counter Ejector System	○	○	●
自動捆紮機/Auto. Tying Machine	○	○	○

※ [●]標準配備/Standard · [○]可選配備/Optional · [—]無此配備/NON

(規格僅供參考·如有變動恕不另行通知/The specification is subject to change for improvement without previous notice.)



# KS系列全自動瓦楞糊盒機

KS-Series of Auto. Folder Gluer(Corrugated Board)

型號 Model: KS-1350/1350W/1350S

## 設備介紹 Equipment Introduction

KS系列全自動瓦楞糊盒機，整機結構及電控均採用模組化設計，便於生產及維護，特殊的結構設計能夠解決瓦楞箱成型工藝過程中常見的問題。適用於紙板、瓦楞箱的黏合。  
The KS series of Auto. Folder Gluer are designed and ideal for laminated corrugated board up o BE Flute to avoid fish-tail problem.

## 機器特性 Main Features



### 給紙部 Feeder Section

平整出紙不歪斜，配有吸風裝置與打孔皮帶、電控左右擋板、氣壓式輔助給紙刀、輔助撐紙架與監控螢幕。  
Correct feeding without skewness. Equipped with suction and hole-belts. Electrically control left and right baffles. Support by pneumatic auxiliary feeding knives and holder and a monitor screen.



### 本折部 Final-Folder Section

多角度導輪與大尺寸折帶，配置大功率馬達，生產三層與五層瓦楞紙箱使摺盒更穩定。  
Multi-angle guide wheels and large-size folding belts are equipped with high-power motors to produce 3-layer and 5-layer corrugated boxes more stably.



### 輸送部 Pressing Conveyor Section

重型輸送機操作迅速便捷，確實給壓不彈開，電子感應自動調整輸送機速度來配合主機運轉速率。  
Heavy structure of Delivery for fast adjustment to offer excellent pressure without re-opening issues. Electrical sensor control to automatically adjust the delivery speed working with the main machine.

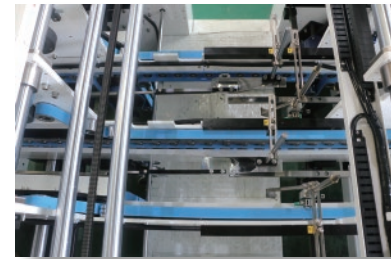

### 勾底部 Crash-Lock Bottom Section

氣壓式上壓桿，可配合勾底盒型變更長度，加上高剛性彈簧勾子座以穩之勾底方式高速作業。  
The pneumatic Upper Pressing Bar is changeable according to the length of crash-lock bottom design. Coupled with the high hardness of hooker-spring base, the high-speed production of crash-lock bottom can be achieved.



### 壓著部 Trombone Section

採用獨立馬達控制，左右板均可單獨調速，能通過皮帶差進一步強化糾正效果，且能夠通過速度差拉開紙盒與前端的距離，保證產品能夠平順生產不撞紙。  
The upper and lower belt carriers are by independently electric controlled. With independent motor, the speed of left and right belt can be adjusted separately. Through the speed difference to have the correction on the gap of front edge of blanks to ensure smooth production without hitting paper.



### 計數堆疊排出系統 (KS-1350S) Counter Ejector System

KS-1350S採用計數堆疊輸送機替代重型輸送機，可高速且穩定的完成指定數量之堆疊，並且可直接與自動捆紮機連接進行包裝作業，使產線升級更加自動化。  
The machine could complete the certain number of stacks at high speed stably. In addition, it is able to connect directly to Auto. Tying machine for packaging operation, which upgrades the production line more automated

## 效率提升 Efficiency Improvement

我們在設備上注重更多細節，有效降低損耗、提升生產良率、人員操作便捷，省時省力高產能。  
We take care of much more details on design and manufacturing of equipment for high efficiency and reduce losses. Improve production to save time and labor.

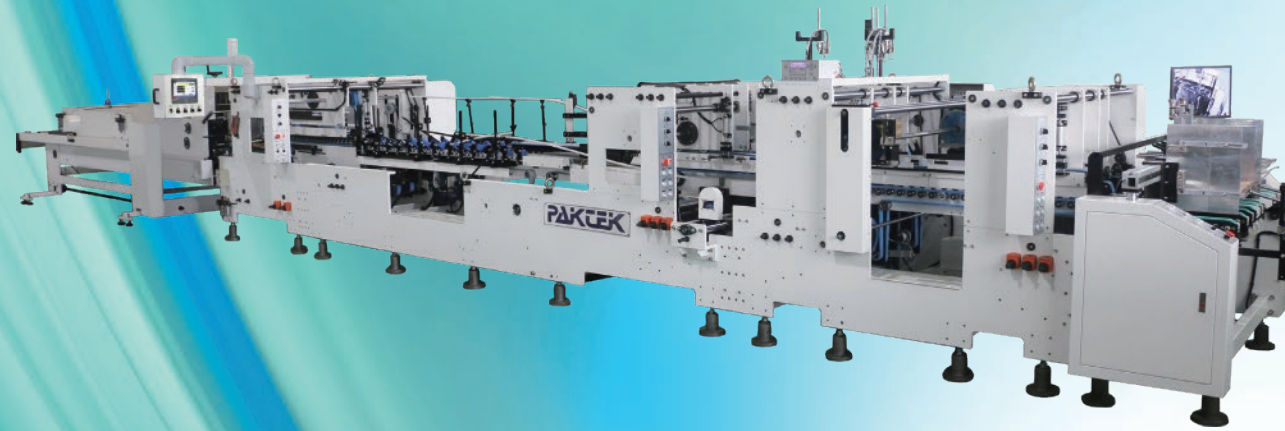

(此圖片僅供參考，請以實際產品為準。 The image shown here is indicative only. The actual product may differ.)



### 1. 壓線輪裝置 Creasing-Wheel Device

紙張經過導正推齊後，能準確壓線，有效減少魚尾公差。  
After Servo Regulator Section, the creasing lines are re-enforced by Creasing-Wheel Device to reduce the fish-tail issue.



### 2. 氣壓式上帶帶板 Air Type of Upper Pressing Bars

可依紙張厚度作氣壓或機械微動調整，使紙張輸送快速穩定且無壓痕。  
According to the paper thickness to make micro adjustment by air cylinder for speedy transportation of blanks without pressing mark.

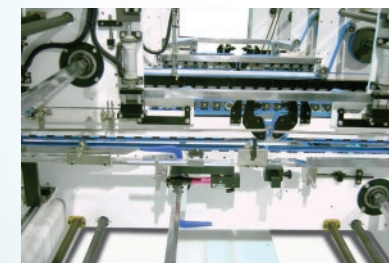

### 3. 四角裝置 4-Corner Attachment

四角盒尺寸設定簡單容易，後踢動作精確穩定快速。  
Very easy to set up 4-corner size for accurate and fast action of back fingers.



### 4. 輸送機電控系統 Pressing Conveyor by Motorization System

輸送機電控調整：做動迅速確實，省時省力。  
Adjustment of Pressing Conveyor by motorization for fast change-over to save time and effort.



### 5. 遠端遙控器 Wireless Remote Controller

採遠端無線遙控功能操作，所需的功能皆能在遙控器上實現。  
By Wireless Remote Control, all the required function can be achieved.

## 選購配件 Optional

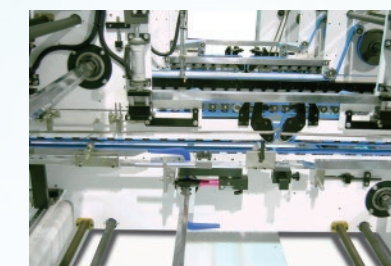

### 四角裝置 4-Corner Attachment

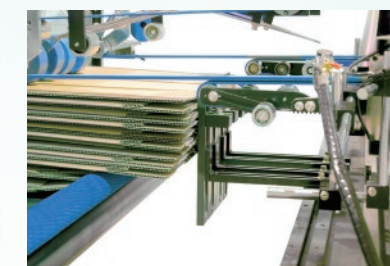

### 堆疊拍齊裝置 The Down Stacking with Square Device



### Plasma等離子處理機 Plasma Treater



### UV磨邊器 UV Grinder

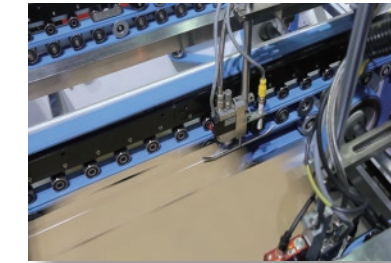

### 自動噴膠系統 Auto. Glue Injection System



### CE安全規格 CE Certificate



### 膠帶貼盒系統 Taping System

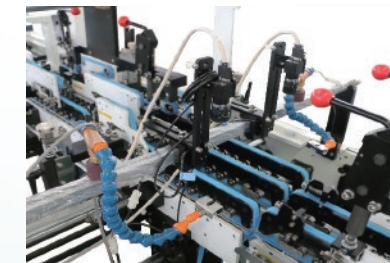

### 影像檢測系統 Quality Assurance System



### 自動捆紮機 Auto. Tying Machine

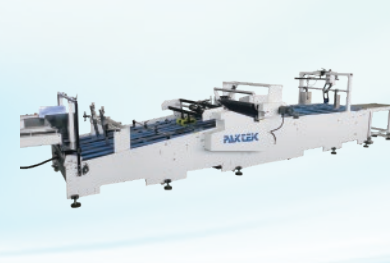

### 計數堆疊排出系統 Counter Ejector System

## 可運用包裝商品類型 Packaging Product Examples

Packaging Product Examples



### 三層瓦楞紙箱 3-Ply Corrugated Board



### 大型紙箱 Large Carton



### 家電紙箱 Home Appliance Carton



### 包裝紙箱 Packaging Corrugated Box